



GenerationRFID
Test & Embedded Electronics
Make it real

lynx53

Test board for automotive products

24 channel switch matrix for EOL
and impedance measurements.

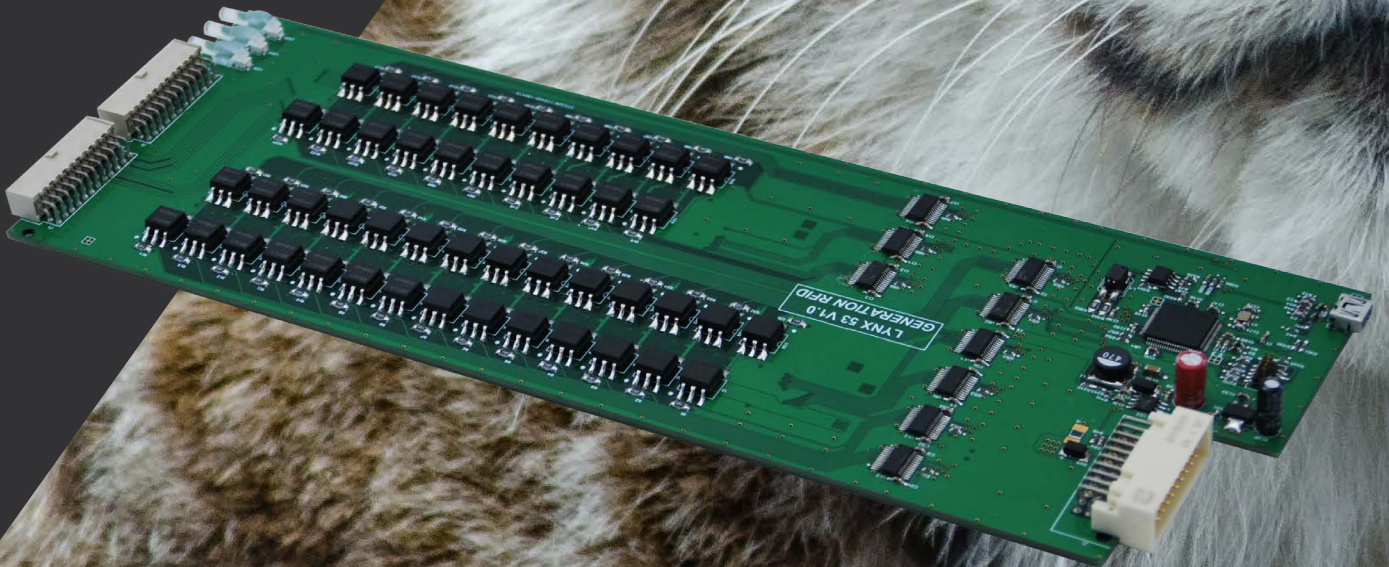

INTRODUCTION

Lyn53 is an electronic board used in high speed EOL testers when the impedance between pins of the DUT must be measured. It is based on ultrafast solid state relays (SSR). This way, minimum switching time and unlimited operations can be assured. Due to its internal design, each DUT pin can be addressed to any of the following contacts:

- Backplane +
- Backplane -
- Bypass to a mirror connector.

FEATURES

- Board size: 295 x 100 mm.
- Rackable board for 19" subracks.
- Expandable when combined with Lynx backplanes.
- CAN and USB controlled.
- Compatible with Lynx Test Scheduler software.
- 72 solid state relays for addressing up to 24 pins.
- Maximum driving capability: 2A per relay.
- Main markets: automotive and industrial.
- Power supply ranging from +6.8V to +30V.

BLOCK DIAGRAM

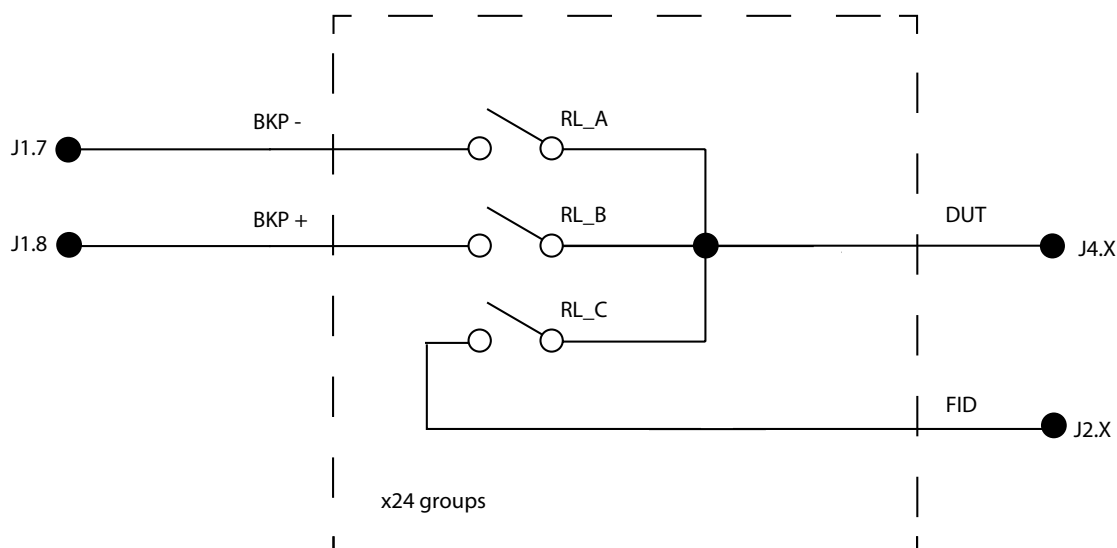

NOMENCLATURE

- DUT: Device Under Test.
- SSR: Solid Stat Relay.
- FID: Function Injection Device (device used to activate any DUT IO pin a certain signal with the objective to validate the associated funcion, e.g. ditigal input, analog input or power output).
- BKP: backplane.

APPLICATIONS

Lynx53 is the first interface between the DUT and the FID and allows an easy implementation of any of the following features:

- EOL fuctional testing for electronic modules.
- ICT testing with external DMM.
- Impedance testing between DUT adjacent pins.
- Short circuit detection.
- Cables validaton.
- Signal injection integrity supervision.

APPLICATION EXAMPLES

- 1** Impedance and short circuit detection between pins.



When a DMM is connected to the backplane, the impedance between DUT pins can be measured. Its flexibility allows the measurement between pins or in regards of the GND pin.

- 2** 4 wire Impedance measurement.

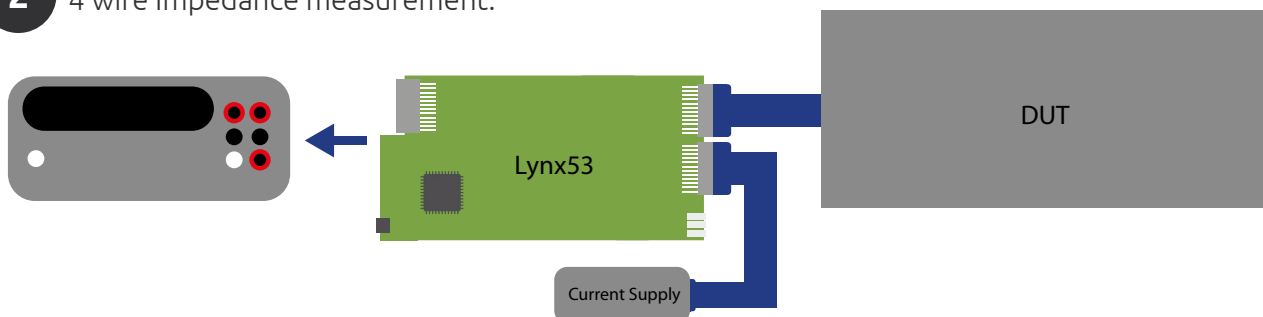

When a current power supply is added to the diagrama number 1, precise measurements can be performed with a basic DMM.

3 HW optimization. Signal communication cost reduction.

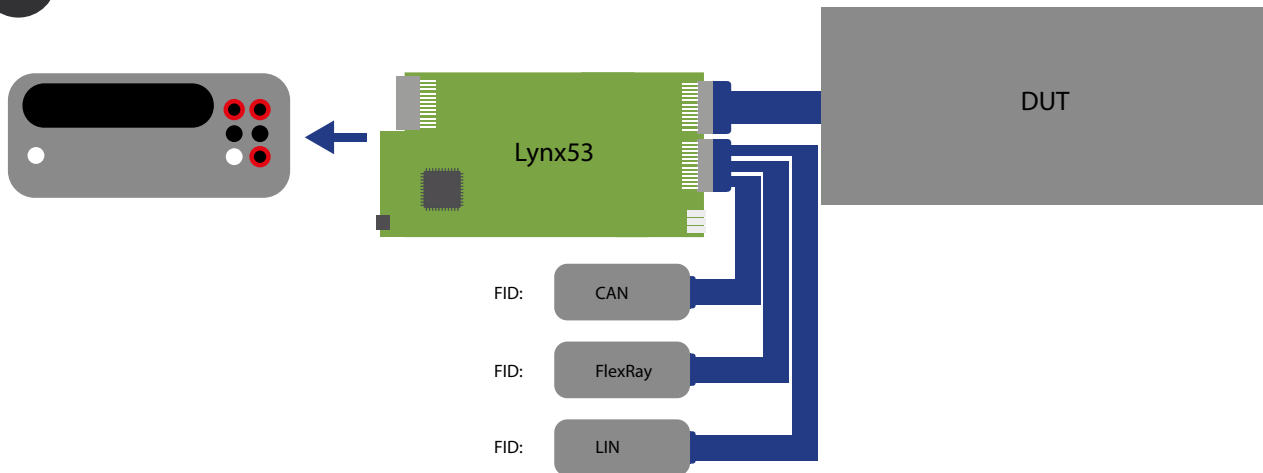

This examples shows how 1 channel communication modules (CAN, LIN, FR, others) can be multiplexed to other CAN lines, reducing the necessity for external modules and the cost for the final tester. This option makes sense when impedance measurement is also required for the test.

4 Signal injection integrity assurance.

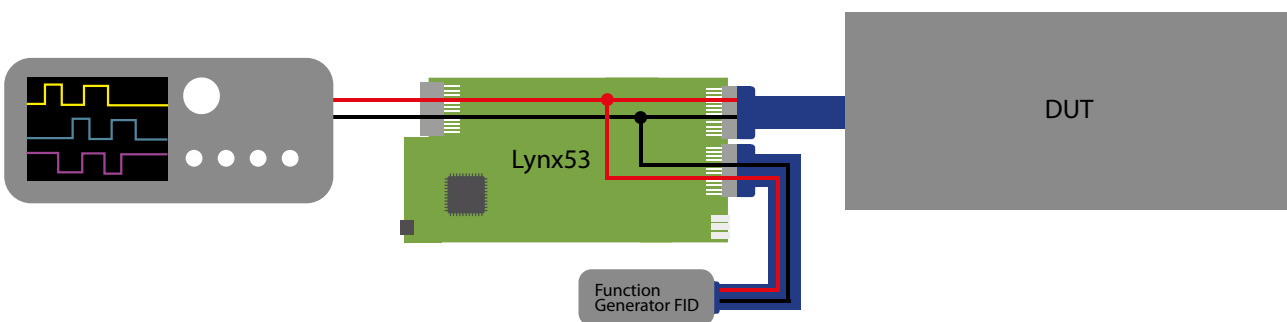

For EOL tests that require specific signals to be injected into a certain pin, an oscilloscope is connected to the backplane for synchronization and signal integrity monitoring purposes.

ELECTRICAL CHARACTERISTICS

ABSOLUTE MAXIMUM RATINGS (Tamb = 25 °C, unless otherwise specified)				
PARAMETER	TEST CONDITION	SYMBOL	VALUE	UNIT
DC or peak AC load voltage J2, J4		VL	60	V
Load current (DC only)		IL	2	A
Output Ron max per channel		Ron	0,3	Ω
Peak load current (AC/DC)	t = 10 ms	ILPK	3.6	A
Per each output, the following derating applies*	25°	Pdiss	250	mW
Ambient temperature range		Tamb	-25 to +85°	°C
Absolute maximum rating curve*				
Power supply			12	V
Current consumption			0,65	A

*Absolute maximum rating curve.

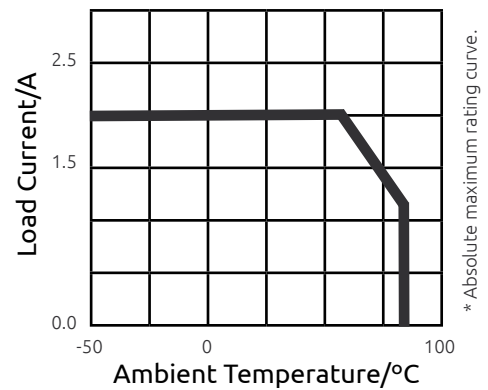
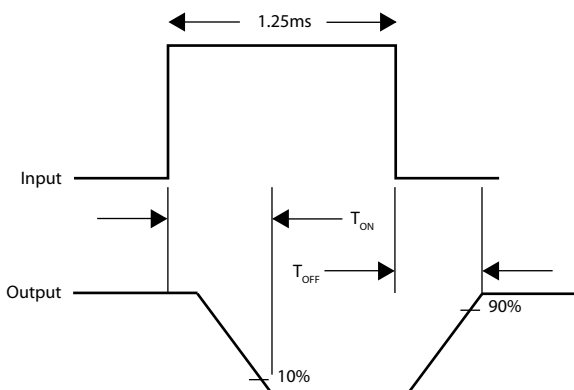

* Absolute maximum rating curve.

SWITCHING CHARACTERISTICS						
PARAMETER	TEST CONDITION	SYMBOL	MIN.	TYP.	MAX.	UNIT
Turn-on time	VL = 16V, IL = 100 mA	ton	-	370	800	μs
Turn-off time	VL = 16V, IL = 100 mA	toff	-	50	800	μs



PINOUT

PINOUT: Lynx53 has 4 connectors.

- J1: Connection with the standard interfaces of the Lynx Tester backplane modules.
- J2: Use this connector for injection of primary signals used for the EOL test.
- J3: USB standard connector.
- J4: Use this connector to connect with the DUT.

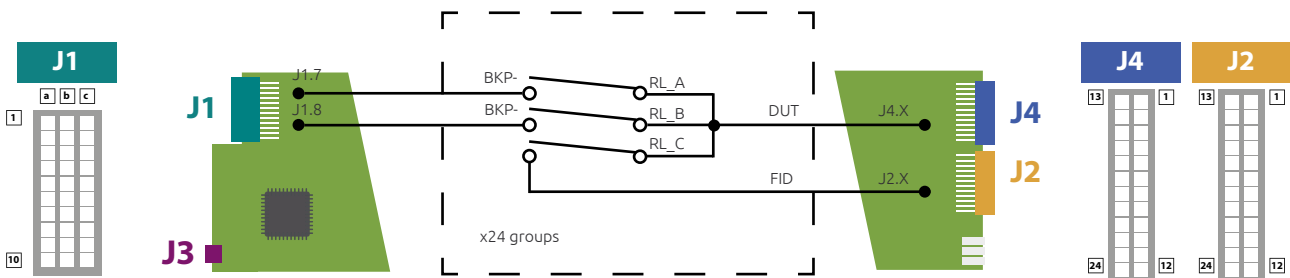

J4	J4.13	GPIO_DUT_13	J4.1	GPIO_DUT_1
	J4.14	GPIO_DUT_14	J4.2	GPIO_DUT_2
	J4.15	GPIO_DUT_15	J4.3	GPIO_DUT_3
	J4.16	GPIO_DUT_16	J4.4	GPIO_DUT_4
	J4.17	GPIO_DUT_17	J4.5	GPIO_DUT_5
	J4.18	GPIO_DUT_18	J4.6	GPIO_DUT_6
	J4.19	GPIO_DUT_19	J4.7	GPIO_DUT_7
	J4.20	GPIO_DUT_20	J4.8	GPIO_DUT_8
	J4.21	GPIO_DUT_21	J4.9	GPIO_DUT_9
	J4.22	GPIO_DUT_22	J4.10	GPIO_DUT_10
	J4.23	GPIO_DUT_23	J4.11	GPIO_DUT_11
	J4.24	GPIO_DUT_24	J4.12	GPIO_DUT_12

J2	J2.13	GPIO_FID_2	J2.1	GPIO_FID_14
	J2.14	GPIO_FID_1	J2.2	GPIO_FID_13
	J2.15	GPIO_FID_15	J2.3	GPIO_FID_3
	J2.16	GPIO_FID_16	J2.4	GPIO_FID_4
	J2.17	GPIO_FID_17	J2.5	GPIO_FID_5
	J2.18	GPIO_FID_18	J2.6	GPIO_FID_6
	J2.19	GPIO_FID_19	J2.7	GPIO_FID_7
	J2.20	GPIO_FID_11	J2.8	GPIO_FID_23
	J2.21	GPIO_FID_10	J2.9	GPIO_FID_22
	J2.22	GPIO_FID_24	J2.10	GPIO_FID_12
	J2.23	GPIO_FID_9	J2.11	GPIO_FID_21
	J2.24	GPIO_FID_8	J2.12	GPIO_FID_20

J1	J1.1a	CAN CTRL H	J1.1b	CAN CTRL L	J1.1c	-
	J1.2a	-	J1.2b	-	J1.2c	-
	J1.3a	GND	J1.3b	GND	J1.3c	GND
	J1.4a	Vsupply Ctrl	J1.4b	Vsupply Ctrl	J1.4c	Vsupply Ctrl
	J1.5a	-	J1.5b	-	J1.5c	-
	J1.6a	-	J1.6b	-	J1.6c	-
	J1.7a	BKP-	J1.7b	BKP-	J1.7c	BKP-
	J1.8a	BKP+	J1.8b	BKP+	J1.8c	BKP+
	J1.9a	-	J1.9b	-	J1.9c	-
	J1.10a	-	J1.10b	-	J1.10c	-

RELAY SWITCH MATRIX

The following table indicates the way the relays are internally connected. As an example, the first row must be understood as indicated below:

- J4:1 is the channel which is connected with the DUT.
- U60 bypasses the signal from the J4:1 to the pin J2:14.
- U36 connects the J4:1 signal to the pin BKP- (J1:7).
- U12 connects the J4:1 signal to the pin BKP+ (J1:8).

BKP+	BKP-	Bypass	
U12	U36	U60	● ← J4.1 ● → J2.14
U14	U38	U62	● ← J4.2 ● → J2.13
U9	U33	U57	● ← J4.3 ● → J2.3
U7	U31	U55	● ← J4.4 ● → J2.4
U5	U29	U53	● ← J4.5 ● → J2.5
U3	U27	U51	● ← J4.6 ● → J2.6
U1	U25	U49	● ← J4.7 ● → J2.7
U22	U46	U70	● ← J4.8 ● → J2.23
U24	U48	U72	● ← J4.9 ● → J2.22
U19	U43	U67	● ← J4.10 ● → J2.12
U17	U41	U65	● ← J4.11 ● → J2.21
U15	U39	U63	● ← J4.12 ● → J2.20

BKP+	BKP-	Bypass	
U11	U35	U59	● ← J4.13 ● → J2.2
U13	U37	U61	● ← J4.14 ● → J2.1
U8	U32	U56	● ← J4.15 ● → J2.15
U8	U32	U56	● ← J4.16 ● → J2.16
U6	U30	U54	● ← J4.17 ● → J2.17
U4	U28	U52	● ← J4.18 ● → J2.18
U2	U26	U50	● ← J4.19 ● → J2.19
U21	U45	U69	● ← J4.20 ● → J2.11
U23	U47	U71	● ← J4.21 ● → J2.10
U20	U44	U68	● ← J4.22 ● → J2.24
U18	U42	U66	● ← J4.23 ● → J2.9
U16	U40	U64	● ← J4.24 ● → J2.8

CONTROL COMMANDS

- ISO 14229-1 (UDS services) for diagnostic and control.
- ISO 15765-2 (ISO-TP) for transport and network.
- Baud rate: 500Kb.
- Data link layer: 11 bits for the ID.
- For Tx frames, ID is calculated by adding 1000d to the last 2 digits of the SN of the board.
- For Rx frames, ID is calculated by adding 1100d to the last 2 digits of the SN of the board.
- DLC: 8 Bytes.

Byte 0	Byte 1	Byte 2	Byte 3	Byte 4... Byte n
DLC	SID	DID		0x19

DID LIST

#	DID	Description	Format
1	0x F7 01 (WRITE 0x2E)	Enable relay	<p>0x 2E F7 01 1D => 0x1D means 0d29, The relay Number 29.</p> <p>The NumberRelay Parameter goes from 0x01 until 0x48 (0d72).</p> <p>Returns [110 , 247 , 1 ,] => OK</p>
2	0x F7 00 (WRITE 0x2E)	Disable relay	<p>0x 2E F7 00 2A => 0x2A means 0d42, The relay Number 42.</p> <p>The NumberRelay Parameter goes from 0x01 until 0x48 (0d72).</p> <p>Returns [110 , 247 , 0 ,] => OK</p>
3	0x F7 03 (WRITE 0x2E)	Disable All relay	<p>0x 2E F7 03 00</p> <p>Returns [110 , 247 , 0 ,] => OK</p>
4	0x F7 02 (READ)	Get Relays State	<p><u>Return Example:</u></p> <p>[98, 247, 2, 255 , 255 , 255 , 255 , 255 , 255 , 255 , 251 , 255 , 255 , 252 , 255 , 255 , 255 , 255 , 255 , 255 , 255]</p> <p><u>Where Relay states are represented following the sequence:</u></p> <p><i>RelayState(0-3), RS(4-7), RS(8-11), RS(12-15), RS(16-19), RS(20-23), RS(24-27), RS(28-31), RS(32-35), RS(36-39), RS(40-43) RS(44-47), RS(48-51), RS(52-55), RS(56-59), RS(60-63), RS(64-67), RS(68-71)</i></p> <p><u>And the bits correspond to:</u></p> <p>251 = 0x 1111 1011 => 11 means OFF; 10 means ON Relay(31)=11; Relay(30)=11; Relay(29)=10; Relay(28)=11;</p>

5	0xF7 05 (WRITE 0x2E)	<p>(CAN_MANUFACTURER_SET_SERIAL)</p> <p>Sets a new Rx ID and Tx ID CAN in function of a serial number. When it sets a new serial number this is saved in NVM and new CAN RX id and TX id are calculated.</p> <p>New CAN RX ID will be: $1000 + (\text{Serial_Number} \& 0xFF)$ New CAN TX ID will be: $1100 + (\text{Serial_Number} \& 0xFF)$</p> <p>For calculating the new CAN ID's are considered only the 2 bytes of less weight of serial number.</p>	<p>0x 2E F7 01 1D => 0x1D means 0d29, The relay Number 29.</p> <p>The NumberRelay Parameter goes from 0x01 until 0x48 (0d72). Returns [110 , 247 , 1 ,] => OK</p>
6	0x F7 09 (WRITE 0x2E)	<p>(CAN_WRITE_ENABLE_WATCHDOG)</p> <p>Enable / Disable Watchdog:</p> <p>When watchdog is enabled, watchdog frames are considered by target board for deactivating all board relays. All relays will be deactivated if in a 10 seconds period watchdog frame are not received.</p>	<p>0x 2E F7 00 2A => 0x2A means 0d42, The relay Number 42.</p> <p>The NumberRelay Parameter goes from 0x01 until 0x48 (0d72). Returns [110 , 247 , 0 ,] => OK</p>
7	0xF7 0B	<p>Set relays by Group and Mask</p> <p>Open/close relays by group (BL+ 00 , BL - 01, ReleCON - 02) and a mask of 24 bits (0 - close, 1 -open).</p> <p>BL+ (relays from 1 to 24)</p> <p>BL- (relays from 25 to 48)</p> <p>RelayCON (relays from 49 to 72)</p> <p>See specs to know pin related to relay number: Lynx53 block diagram and connections</p>	<p>0x2E F7 0B [group] [3 bytes mask]</p> <p>Example 1: 0x2E F7 0B 00 94 92 24 mask bits = 10010100 10010010 01001000 It will close relays to BL + (1,4,6,9,12,15,18,21), and open others to BL+</p> <p>Example 2: 0x2E F7 0B 02 F0 F0 F0 mask bits = 11110000 11110000 11110000</p> <p>It will close relays to ReleCON (1,2,3,4,9,10,11, 12,17,18,19,20), and open others</p>
8	0xF7 0A (WRITE 0x2E)	<p>(CAN_WRITE_REFRESH_WATCHDOG)</p> <p>Refresh Watchdog:</p> <p>This is the frame which has to be sent to the target board continuously. Time between frame and frame doesn't have to exceed from 10 seconds.</p>	<p><u>Watchdog frame: 0x2E F7 0A AA</u></p>

EXAMPLE

- ID: Tx ID: 1055 (0x41F) / Rx ID: 1155 (0x483)
- Goal is to close relay 25
 - ID: 0x41F an Message:

DLC	SID	DID	Data Bytes
0x04	0x02E	0xF7 0x01	0x19

CONTACT INFORMATION

☎ (+34) 877 911 208

✉ info@generationrfid.com



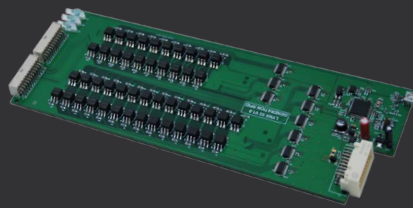

Test board for automotive products
www.generationrfid.com

Powered by:  **GenerationRFID**
Test & Embedded Electronics
Make it real